

# Design and Structural Analysis of Meatball Printing Machine with Arduino Uno-Based Security System for Operator Protection

Bayu Surya Ramadhan<sup>1</sup>, Edi Widodo<sup>1</sup>, A'Rasy Fahrudin<sup>1</sup>, Mulyadi<sup>1</sup>

<sup>1</sup>Department of Mechanical Engineering, Universitas Muhammadiyah Sidoarjo, Jl. Raya Gelam No. 250, Candi, Sidoarjo, Jawa Timur, 61271, INDONESIA

---

## Article Info

### Article history:

Received 06 August, 2025

Revised 10 October, 2025

Accepted 05 November, 2025

## Abstract

This study presents the design and structural verification of a compact meatball-forming machine that integrates an Arduino Uno-based operator protection system. A redesigned 500×500×1011 mm frame made of 20×20×1.5 mm hollow steel was modeled in SolidWorks 2024 and evaluated using finite element analysis (von Mises stress, displacement, strain, and safety factor) under an applied load representing a 30 kg operating condition. To reduce assembly complexity, two alternative concepts were assessed using Design for Assembly (DFA), and the most efficient configuration was selected for detailed development. The safety subsystem employs an HC-SR04 ultrasonic sensor facing the operator zone; when the detected distance falls below 10 cm, the controller triggers a warning indicator and enables protective control actions. The final concept achieved higher DFA efficiency (18%) than the initial concept (16%) while reducing material use and overall footprint. Structural simulations indicate a peak von Mises stress of 163.6 MPa, below the 250 MPa yield strength of ASTM A36 steel, a maximum displacement of 1.002 mm, and a minimum safety factor of 1.528, confirming adequate stiffness and margin against yielding. The proposed design combines adjustable forming via an iris mechanism with servo-driven cutting to improve process consistency while embedding real-time proximity sensing to enhance occupational safety.

**Keyword:** Meatball Printing Automation; Operator Safety; Arduino Uno Control

---

### \*Corresponding Author:

Name Bayu Surya

Email: [bayusuryaaaa@gmail.com](mailto:bayusuryaaaa@gmail.com)

---

## 1. Introduction

The development of design practices using SolidWorks software in Indonesia has progressed significantly in recent years. This advancement spans from traditional methods to fully automated systems operated entirely by machines [1]. One approach to introducing the concept of modern

design cycles is through modern design-driven technologies[2].Product design serves as a strategic step aimed at creating industrial products that are commercially viable and capable of providing an optimal rate of return on investment [3]. The use of software for technical drawing in industry such as SolidWorks offers extensive design features supported by motion simulation, mechanical analysis, and various other simulation tools [4].SolidWorks is also one of the most widely used CAD applications in the manufacturing industry for product design purposes [5].The design of a meatball-forming machine represents an innovative step to improve efficiency and consistency in meatball production. This production process aims to enhance overall efficiency and effectiveness[6], thus requiring the integration of appropriate technologies to support its operation [7].In practice, meatball makers generally still rely on manual shaping methods. However, this traditional approach has several drawbacks, particularly in terms of time consumption and labor intensity [8].Therefore, a challenge arises to develop an innovative solution that integrates modern technological advancements [9].

Previous studies have predominantly focused on production efficiency and the quality of the meatballs produced, yet have paid relatively little attention to operator safety during the production process. The Arduino Uno serves as the main controller of the entire system [10]. in efforts to enhance both machine safety and operational effectiveness [11].The HC-SR04 ultrasonic sensor is commonly used as a distance sensor [12], operating by allowing the Arduino Uno microcontroller to process distance measurements obtained from the ultrasonic module [13]. Arduino, as an open-source microcontroller platform, is easily programmable and can be updated at any time [14]. This hardware platform, widely recognized for its flexibility, is capable of collecting data from various sensors, transmitting information via communication modules, and controlling devices through actuators [15]. In this system, the sensor is mounted at the front section of the machine, where it receives and processes distance data[16].The development of a meatball-forming machine equipped with an Arduino Uno-based safety system centers on structural analysis conducted using SolidWorks 2024 one of the most influential computer-aided engineering technologies in the field of mechanical engineering [17]. This analysis includes von Mises stress, displacement, strain, and safety factor evaluations. The use of SolidWorks greatly assists designers in estimating shape, dimensions, material selection, and structural strength [18].

This study focuses on the design of a meatball-forming machine equipped with an Arduino Uno-based safety system. The problem formulation includes developing the machine design, conducting von Mises stress, displacement, strain, and safety factor analyses, and implementing the Arduino Uno and HC-SR04 sensor as an operator protection system. The scope of the study is limited to creating the machine design using SolidWorks 2024, performing structural analysis with the same software, and applying a distance sensor to provide safety warnings.Additionally, the machine is equipped with two servo motors to operate the dough-cutting mechanism to prevent the dough from forming an elongated shape, as well as an additional servo to drive an automatic slicing mechanism that regulates the size of the meatball dough. The main objective of this research is to design an efficient and safe meatball-forming machine, ensure structural reliability through mechanical analysis, and enhance workplace safety through distance detection and Arduino Uno-based control mechanisms

## **2. Research Method**

The research methodology used in designing the Arduino Uno-based meatball-forming machine for operator protection involves several essential stages. The overall workflow of the

research is illustrated in the flowchart of the meatball-forming machine design, as shown in Figure 1.

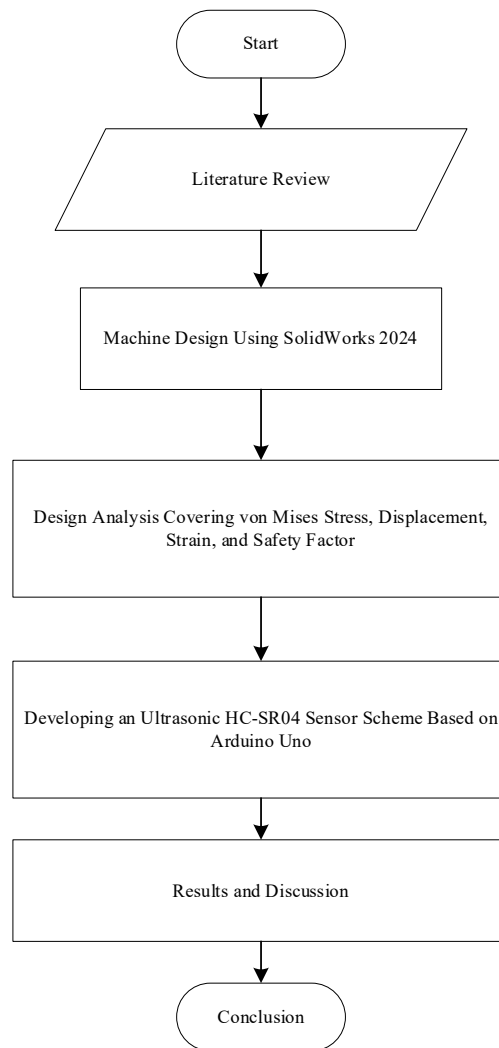

**Figure 1.** Research Flowchart

## 2.1 Research Methodology

The research methodology used in designing the Arduino Uno–based meatball-forming machine for operator protection consists of several key stages. The study begins with a literature review to understand the working principles of meatball-forming machines and the Arduino Uno microcontroller. This is followed by a needs analysis to identify the machine’s required functions, determine operator safety features, and assess potential risks along with their mitigation strategies. The next stage involves concept development, which includes the mechanical design of the machine and the Arduino-based control system. Subsequently, the control system is designed by establishing the Arduino Uno architecture and integrating safety sensors. The developed system is then modeled through computer simulation to validate control performance. During the design optimization stage, efficiency evaluation and refinement are conducted based on the simulation results. Finally, the study concludes with a results analysis and formulation of conclusions regarding the effectiveness, feasibility, and safety level of the proposed meatball-forming machine design.

## 2.2 Conceptual Framework of the Meatball-Forming Machine

The machine frame is designed using 35×35×5 mm angle iron, with overall dimensions of 750×500×1300 mm (L×W×H). A total of 20.8 meters of material is required for the entire frame construction. This material was selected due to its high structural strength, which provides excellent support for the load of the mixing system. The conceptual reference design of the meatball-forming machine is presented in Figure 2.

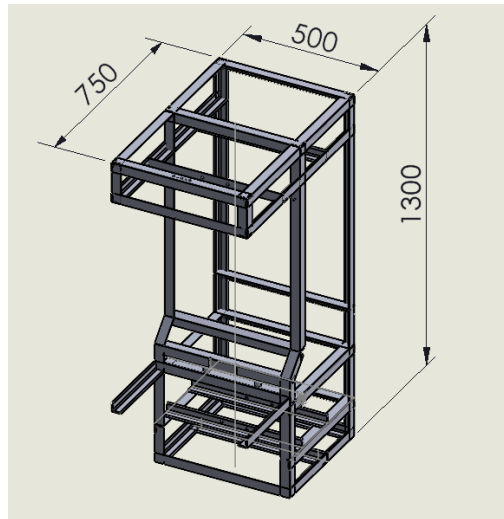

**Figure 2.** Conceptual Reference of the Meatball-Forming Machine

## 2.3 Redesigned Machine Frame

The machine frame is designed using 20×20×1.5 mm hollow steel profiles, with overall dimensions of 500×500×1011 mm. The total material required is approximately 8.5 meters, making it significantly more efficient than the previous design. Hollow steel was selected not only for its cost-effectiveness but also for its adequate structural strength to support the mixing system, ensuring that the machine's functional requirements are still met. The new frame design is presented in Figure 3.

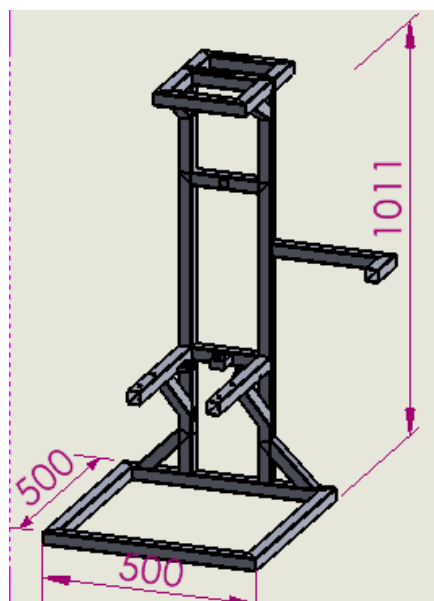
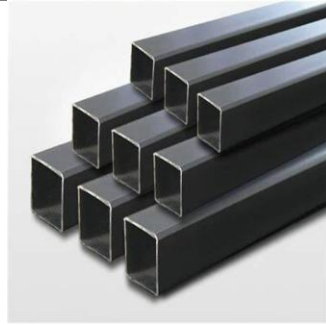

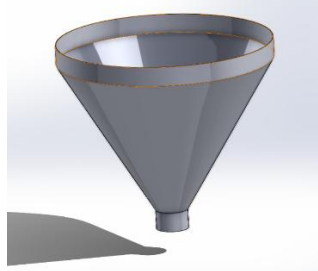

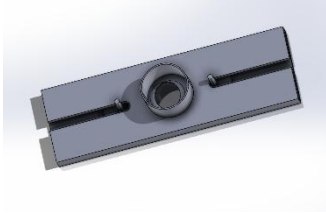
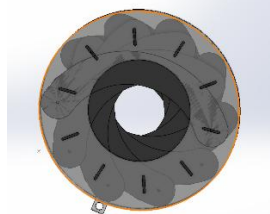

**Figure 3.** Redesigned Machine Frame

### 3. Results And Discussion

Based on the findings of the study on the meatball-forming machine, a list of requirements was compiled to serve as a reference in the product development process. The detailed requirements for the development of the meatball-forming machine are presented in Table 1.

**Table 1.** Component Selection

Subsection	Concept A	Concept B
Materials	 <p data-bbox="582 846 909 884">35×35×5 mm Angle Iron</p>	 <p data-bbox="997 846 1324 884">30×20×1.5 mm Hollow Steel</p>
<i>Hopper</i>	 <p data-bbox="678 1198 885 1232">Capacity 26 Kg</p>	 <p data-bbox="1093 1198 1300 1232">Capacity 11 Kg</p>
Transmission	 <p data-bbox="734 1545 821 1579">Pulley</p>	 <p data-bbox="1053 1545 1340 1579"><i>Worm Gear Reducer</i></p>
Meatball Mold	 <p data-bbox="582 1825 821 1859">Fixed size 30 mm</p>	 <p data-bbox="997 1825 1364 1904">Variable with an iris system 10.5–89 mm</p>

Based on the results presented in Table 1 regarding component selection, the concept demonstrating the highest advantages was chosen for further development into the product design

stage. The following section presents the concept of the meatball-forming machine to be designed. The first concept (Concept A) features a machine frame constructed from stainless steel using  $35 \times 35 \times 5$  mm angle profiles. The frame has dimensions of 750 mm in length, 1300 mm in height, and 500 mm in width. Additionally, the hopper used in this concept has a capacity of 26 kilograms. In Concept A, the machine still employs a manual meatball-forming mechanism. The bill of materials for Concept A is presented in Figure 4.

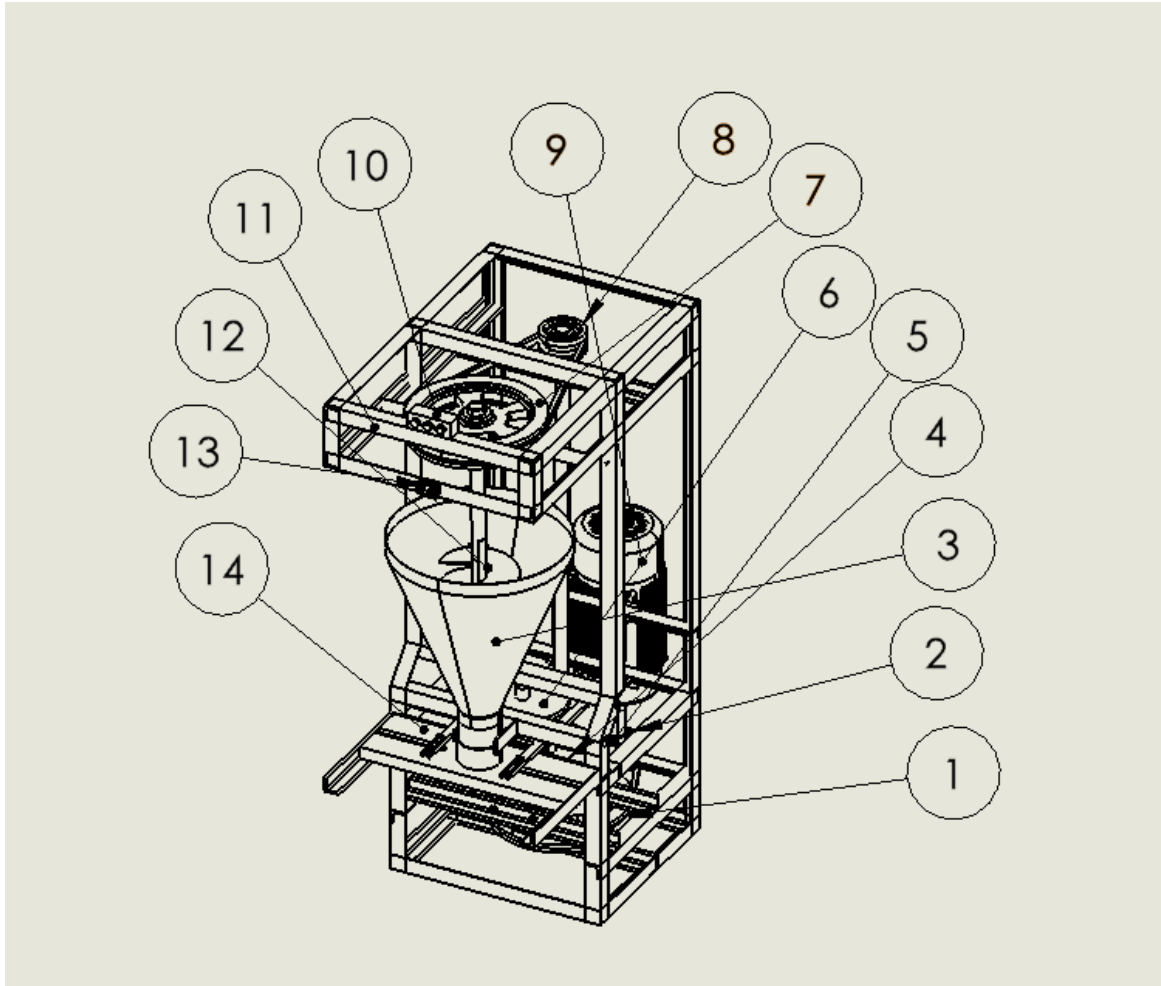

**Figure 4.** The Bill of Materials for Concept A

Description:

- |                           |  |
|---------------------------|--|
| 1. Pulley 10 inch         | 8. Pulley 2 inch                           |
| 2. Pulley 2 inch          | 9. Electric Motor 0,5 Hp                   |
| 3. Hopper Capacity 26 Kg  | 10. Warning LED Light                      |
| 4. Pulley 2 inch          | 11. $35 \times 35 \times 5$ mm Angle Frame |
| 5. Pulley 2 inch          | 12. Dough Extruder                         |
| 6. Cutting Arm Drive Gear | 13. HC-SR04 Ultrasonic Sensor              |
| 7. Pulley 6 inch          | 14. Manual Cutter                          |

### 3.1 DFA (Design for Assembly) Analysis of Machine Design

Design for Assembly (DFA), in simple terms, is the process of designing a product or equipment with the objective of facilitating and improving the assembly process[19].The application of the DFA method aims to produce a more effective meatball-forming machine design with a higher level of efficiency. The detailed results of the analysis and calculations for each component of the Concept A meatball-forming machine can be seen in Table 2.

**Table 2.** Design for Assembly Calculations of Meatball-Forming Machine Concept A

Part ID N <sub>c</sub>	Name Of Assembly	Number Of Time The Operation Is Carried Out Consecutivity	Manual Handling Code	Manual Handling Time Per Part	Manual Insertion Code	Manual Insertion Time Per Part	Operation Time, Second = [(5) + (7)]	Figures For Estimation Of Theoretical Minimum Part
1	Pulley 10 Inch	1	5.0	2.73	5.9	12	14.73	1
2	Pulley 2 Inch	4	4.0	2.73	3.8	6.0	34.92	1
3	Hopper	1	3.0	1.95	0.1	2.5	4.45	1
4	Drive Gear	1	3.0	2.73	5.9	12	14.73	1
5	Pulley 6 Inch	1	3.0	2.73	4.8	8.5	11.23	0
6	Electric Motor	1	9.5	4.0	9.2	5.0	9	1
7	LED Light	1	0.1	1.8	3.8	6.0	7.8	0
8	35×35×5 mm Angle Iron Frame	1	4.1	1.95	9.6	12	13.95	1
9	Meatball Dough Extruder	1	1.1	2.73	3.8	6.0	8.73	1
10	Ultrasonic Sensor	1	1.0	2.25	3.8	6.0	8.25	0
11	Manual Cutter	2	4.1	2.25	4.8	8.5	21.5	1
Total		19					149.29	8
							T <sub>M</sub>	N <sub>M</sub>

$$\text{Design Efficiency (\%)} = \frac{3 \times 8}{149.29} \times 100\% = 0,16 \quad (1)$$

Description:

3 : Theoretical Minimum Time per Part (seconds)

N<sub>M</sub> : *Theoretical Minimum Number of Parts (the minimum number of parts truly required for the product's function)*

T<sub>M</sub> : *Measured Assembly Time (the total actual assembly time, obtained by summing all times in the DFA table)*

The second concept (Concept B) features a machine frame made from 20 × 20 × 1.5 mm square hollow sections. The selection of a smaller frame aims to reduce costs while still maintaining the required structural strength. The frame has dimensions of 500 mm in length, 1011 mm in height, and 500 mm in width. Additionally, the hopper in this concept has a capacity of 11 kilograms. In Concept B, the machine is equipped with an automatic mold featuring an open-and-close mechanism, capable of adjusting the mold opening from 10.5 mm to 89 mm. The bill of materials for Concept B is presented in Figure 5.

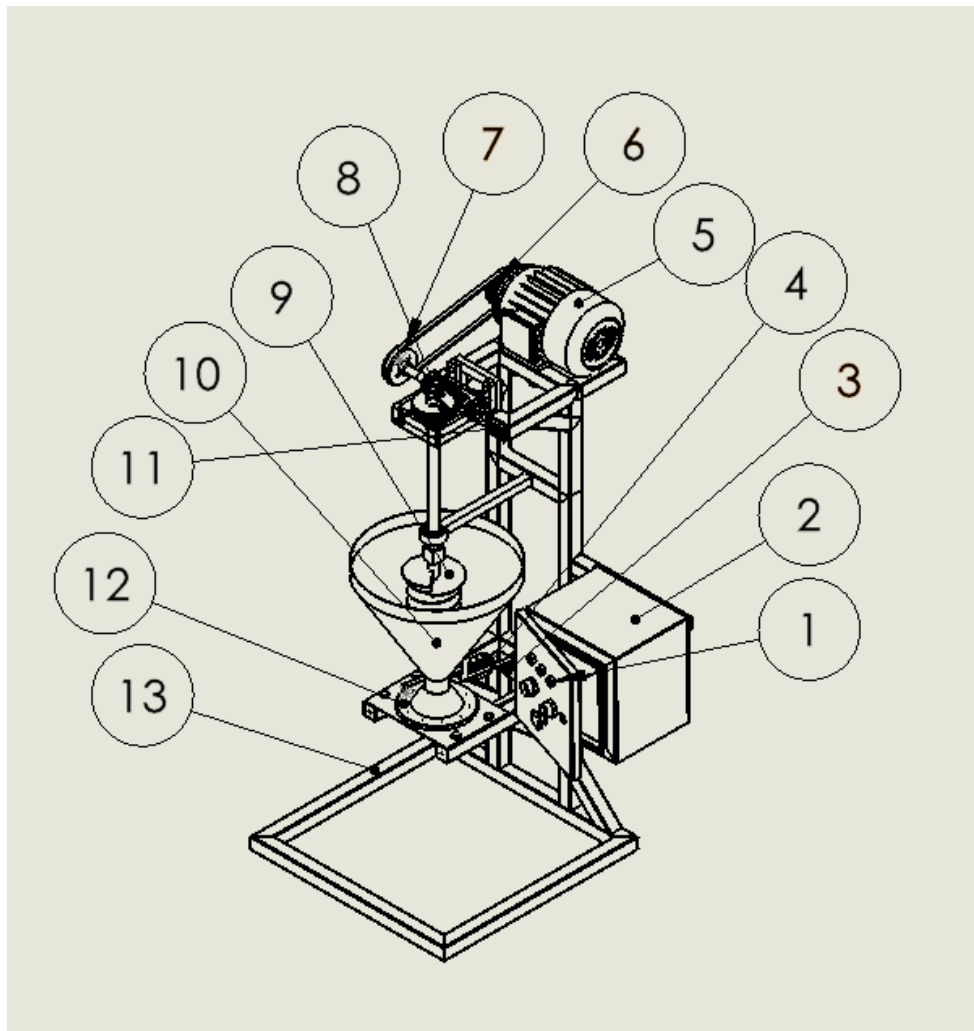

**Figure 4.** The Bill of Materials for Concept B

Description:

- |                               |                                    |
|-------------------------------|------------------------------------|
| 1. Warning LED Light          | 8. Transmission                    |
| 2. Electrical Panel           | 9. Dough Extruder                  |
| 3. Iris Mechanism Drive Servo | 10. Hopper Capacity 11 kg          |
| 4. Cutting Drive Servo        | 11. HC-SR04 Ultrasonic Sensor      |
| 5. Electric Motor 0,5 Hp      | 12. Iris-Based Automatic Mechanism |
| 6. Pulley 3 inch              | 13. Frame 20x20x1,5 mm             |
| 7. Pulley 3 inch              |                                    |

The detailed results of the analysis and calculations for each component of the Concept B meatball-forming machine can be seen in Table 3.

**Table 3.** Design for Assembly Calculations of Meatball-Forming Machine Concept B

Part ID Nc	Name Of Assembly	Number Of Time The Operation Is Carried Out Consecutivity	Manual Handling Code	Manual Handling Time Per Part	Manual Insertion Code	Manual Insertion Time Per Part	Operation Time, Second = [(5) + (7)]	Figures For Estimation Of Theoretical Minimum Part
1	Warning LED Light	1	4.0	3.6	0.1	2.5	6.1	0
2	Electrical Panel	1	8.3	5.6	3.8	6.0	11.6	1
3	Servo	3	5.8	8.0	3.8	6.0	42.0	1
4	Electric Motor	1	9.5	4.0	9.2	5.0	9.0	1
5	Pulley 3 inch	2	4.0	3.6	3.8	6.0	19.2	1
6	<i>Transmission</i>	1	8.3	5.6	3.8	6.0	11.6	1
7	Dough Extruder	1	1.1	1.8	3.8	6.0	7.8	1
8	Hopper	1	3.0	1.95	0.1	2.5	4.45	1
9	Ultrasonic Sensor	1	1.0	1.5	3.8	6.0	7.5	0
10	Iris-Based Automatic Mechanism	1	7.0	5.1	3.8	6.0	11.1	1
11	Frame 20x20x1,5 mm	1	4.1	6.85	9.6	12	18.85	1
Total		14					149.2	9
							T <sub>M</sub>	N <sub>M</sub>

$$\text{Design Efficiency (\%)} = \frac{3 \times 8}{149.29} \times 100\% = 0,18 \quad (2)$$

Based on the DFA analysis, Concept A recorded an assembly time of 149.29 seconds with an efficiency of 16%, while Concept B had an assembly time of 149.2 seconds with an efficiency of 18%. This indicates that although both concepts have nearly identical assembly times, Concept B is slightly more efficient than Concept A. With higher efficiency, Concept B demonstrates the potential for a simpler and more effective assembly process, making it more advantageous in terms of productivity and assembly cost.

### 3.2 Structural Simulation

After completing the machine frame design, the next step is to perform a structural simulation. The material used in the analysis is ASTM A36 steel, and the load is applied to specific areas of the machine frame. The results of the strength analysis for the selected frame design are presented in Figures 6, 7, 8, and 9.

#### 1. Von Mises Simulation Results

The colors shown in Figure 6 of the frame represent Von Mises stress values. The highest Von Mises stress occurs at the center of the frame joint, indicated by yellow to orange colors, with values ranging from 147,216,832.000 N/m<sup>2</sup> to 163,574,256.000 N/m<sup>2</sup>. These values are still below the material's yield strength of 250,000,000.000 N/m<sup>2</sup>, indicating that the frame structure is considered safe. The Von Mises stress analysis results are shown in Figure 6.

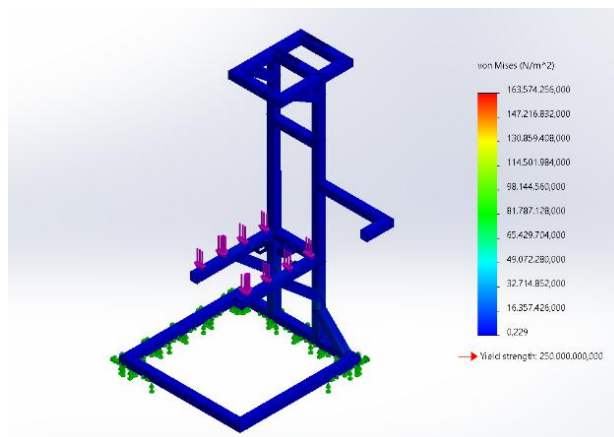

**Figure 6.** Von Mises stress analysis results

#### 2. Displacement Simulation Results

The colors shown in Figure 7 of the frame represent displacement (total deflection) values. The maximum displacement occurs at the top of the frame, indicated by the red color, with a displacement value of 1.002 mm. Meanwhile, the bottom part of the frame, shown in blue, experiences minimal displacement of 0 mm, indicating that this area remains relatively stable and does not undergo significant deformation under the applied load. The displacement analysis results are presented in Figure 7.

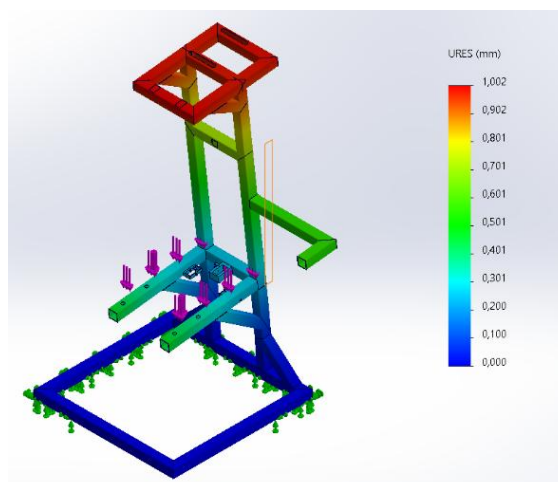

**Figure 7.** Displacement analysis results

### 3. Strain Simulation Results

In Figure 8, the highest strain occurs at the top of the frame joint, indicated by the red color, with a strain value of 0.000376. Meanwhile, the bottom part of the frame, shown in blue, experiences a very small strain of 0, indicating that this area does not undergo significant deformation under the applied load. The strain analysis results are presented in Figure 8.

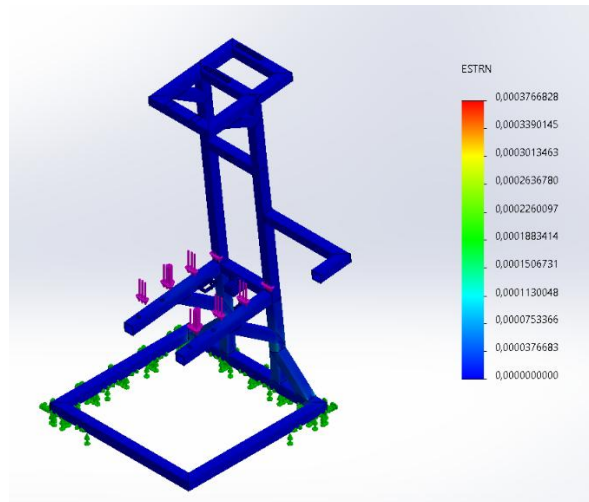

**Figure 8.** Strain analysis results

### 4. Safety Factor Simulation Results

The lowest Safety Factor occurs at the middle frame joint, indicated by the red color, with a minimum value of 1.528. This Safety Factor value indicates that the structure is still considered safe. If the Safety Factor falls below 1, the component or product is deemed unsafe, potentially prone to failure during use, and could endanger the operator[20]. Therefore, the minimum value of 1.528 remains above the safety threshold. The Safety Factor analysis results are shown in Figure 9.

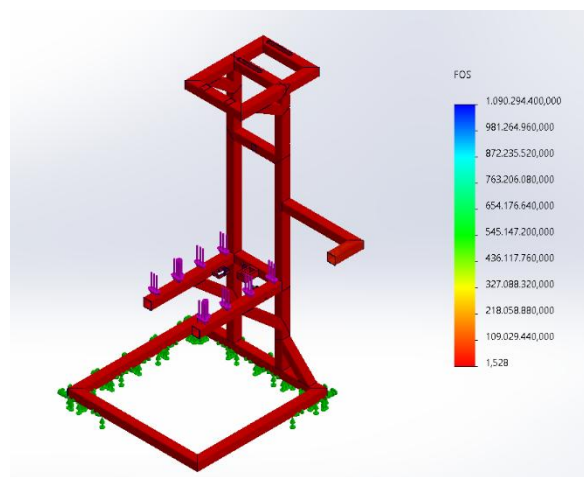
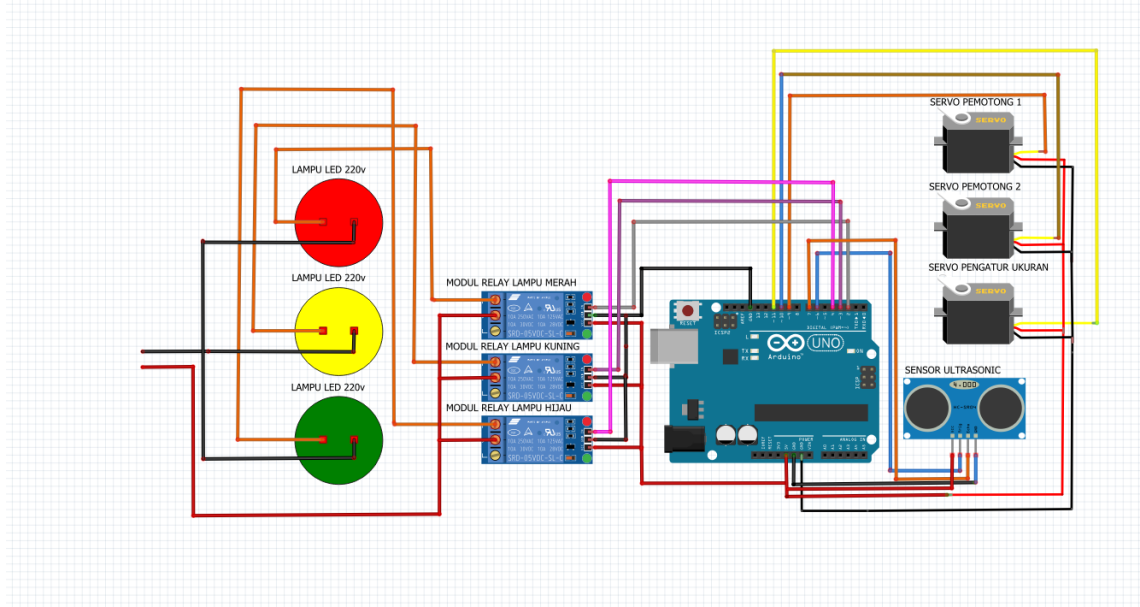

**Figure 9.** Safety Factor analysis results

## 3.3 Implementation of Arduino Uno

The operator protection system is designed using an Arduino Uno microcontroller as the central control unit and an HC-SR04 sensor to detect the presence of objects or humans within the

working area. The sensor is positioned facing the operator area and will activate a warning through a red LED light if a distance of less than 10 cm is detected. In addition to the safety system, the design also incorporates servo motors that function as dough cutters and meatball size adjusters, with servo movements controlled by the Arduino based on programmed activation time and rotation angles. The schematic of the Arduino system is shown in Figure 10.



**Figure 10.** Arduino Uno System Circuit

Simulation using Wokwi is employed to test the circuit and program virtually before implementation on the actual device. Through this platform, the functions of the Arduino Uno, HC-SR04 sensor, LED, and servos can be verified in advance, as shown in Figure 11.

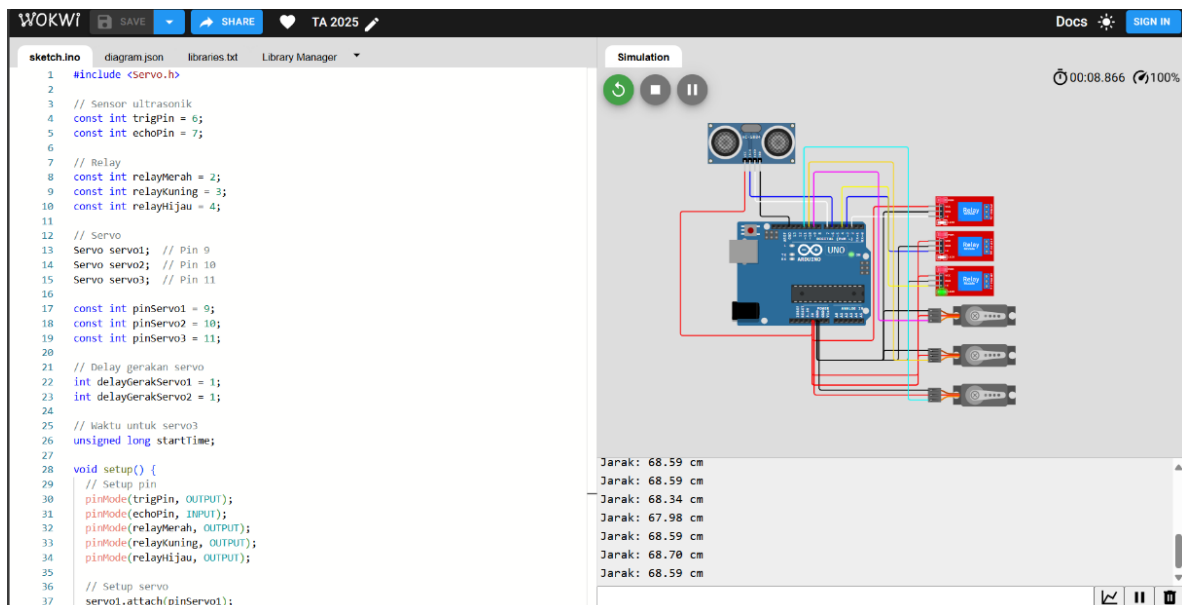

**Figure 11.** Simulation Using Wokwi

<https://wokwi.com/projects/429753926451653633>

## 4. Conclusion

This study demonstrates that Concept B better meets the design objectives for the Arduino Uno-based meatball-forming machine with a safety system, as it is more compact, efficient, and material-saving compared to the initial design, and is equipped with servo-based automatic forming and cutting mechanisms. Structural analysis using von Mises stress, displacement, strain, and safety factor methods shows that the 20×20×1.5 mm hollow frame can safely withstand loads of up to 30 kg, without approaching the material's yield limit. In addition, the implementation of the Arduino Uno and HC-SR04 sensor significantly enhances workplace safety, as the sensor detects the presence of operators or objects in hazardous areas and automatically stops the system when a potential risk is detected. Therefore, the final design is not only effective for the meatball-forming process but also structurally robust, safe, and compliant with operator protection standards.

## Acknowledgements

I would like to express my deepest gratitude to the Mechanical Engineering Study Program at Universitas Muhammadiyah Sidoarjo for all the knowledge, guidance, and valuable experiences I have gained throughout my studies and during the preparation of this research. I also extend my sincere thanks to my fellow colleagues who have continuously provided support, advice, and assistance, enabling this research to be successfully completed. May all the kindness and contributions given be of lasting benefit to all parties involved.

## References

- [1] A. M. Siregar, C. A. Siregar, and K. Umurani, "Desain Dan Pembuatan Mesin Pengaduk Srikaya Guna Membantu Meningkatkan Produktivitas Usaha Toko Roti di Kota Berastagi Sumatera Utara," *Ihsan J. Pengabd. Masy.*, vol. 4, no. 1, 2022, doi: 10.30596/ihsan.v4i1.9970.
- [2] A. Prasetyadi *et al.*, "Pandangan Siswa Terhadap Desain Berbantuan Komputer Dalam Pelatihan Solidworks Di Smk Nusantara Kudus," *Abdimas Altruus J. Pengabd. Kpd. Masy.*, vol. 5, no. 1, pp. 42–46, 2022, doi: 10.24071/aa.v5i1.3892.
- [3] G. F. N. A. GARIN and Y. Anton Nugroho, "Perancangan Alat Perancangan Alat Penggulung Benang Menggunakan Metode Vdi 2221 Pada Ukm Kf Kayra," *J. Ilm. Tek. Mesin, Elektro dan Komput.*, vol. 2, no. 3, pp. 130–135, 2022, doi: 10.51903/juritek.v2i3.394.
- [4] W. D. Lestari, L. Edahwati, and N. Adyono, "Pelatihan CAD Static Simulation Menggunakan Solidworks di SMK Turen Malang," *E-Dimas J. Pengabd. Kpd. Masyarakat; Vol 13, No 4 E-Dimas; 757-761; 2528-5041; 2087-3565*, 2022, [Online]. Available: <http://journal.upgris.ac.id/index.php/e-dimas/article/view/12802>
- [5] F. Kurniawan *et al.*, "Program Pelatihan Perancangan Desain Universal Joint Sederhana Menggunakan Solidworks Kepada Para Guru di SMK Turen," *Abdi-mesin J. Pengabd. Masy. Tek. Mesin*, vol. 2, no. 1, pp. 46–55, 2022, doi: 10.33005/abdi-mesin.v2i1.31.
- [6] E. Prasetyo, R. Hermawan, M. N. I. Ridho, I. I. Hajar, H. Hariri, and E. A. Pane, "Analisis Kekuatan Rangka Pada Mesin Transverse Ducting Flange (TDF) Menggunakan Software Solidworks," *Rekayasa*, vol. 13, no. 3, pp. 299–306, 2020, doi: 10.21107/rekayasa.v13i3.8872.
- [7] F. Faujiyah and N. Sidik, "Perancangan Rangka Mesin Pencacah Cipuk (Aci Kerupuk)," *J. TEDC*, vol. 14, no. 1, pp. 29–34, 2020, [Online]. Available: <https://ejournal.poltektedc.ac.id/index.php/tedc/article/view/343>
- [8] N. S. Saputra, M. Muchlisinalahuddin, and A. Armila, "Rancang Bangun Mesin Pencetak Bakso," *J. Tek. Mesin*, vol. 15, no. 2, pp. 115–120, 2022, doi: 10.30630/jtm.15.2.859.
- [9] A. R. Prasetyo, S. Yulianto, and E. Widodo, "Rancangan Prototipe Mesin Pengering Gabah Berbasis Teknologi Hybrid Prototype Design of Grain Dryer Machine Based on Hybrid

- Technology,” *J. Konversi Energi dan Manufaktur*, vol. 9, no. 1, pp. 32–42, 2024.
- [10] Rizky Wahyu Pradana, Ganjar Febriyani Pratiwi, and Tri Nur Arifin, “Rancang Bangun Sistem Pemantau Ketinggian Air Otomatis Menggunakan Sensor Ultrasonik (Hc-Sr04) Berbasis Arduino Uno Dengan Antarmuka Komputer Berbasis Microsoft Visual Basic 6.0,” *J. Tek. dan Sci.*, vol. 3, no. 1, pp. 13–24, 2024, doi: 10.56127/jts.v3i1.1212.
- [11] A. F. Zulkarnain and M. Mulyadi, “Design and Cost of Pandan Chopping Machine Components with an Electric Motor Drive,” *Indones. J. Cult. Community Dev.*, vol. 15, no. 2, Jun. 2024, doi: 10.21070/ijccd.v15i2.1183.
- [12] A. H. Nadyawan, “Aplikasi Sensor Ultrasonic HC-SR04 Pada Robot Anti Penghalang,” *Semin. Nas. Forte*7-4, pp. 306–312, 2021.
- [13] Y. Irawan, Muhardi, R. Ordila, and R. Diandra, “Automatic floor cleaning robot using arduino and ultrasonic sensor,” *J. Robot. Control*, vol. 2, no. 4, pp. 240–243, 2021, doi: 10.18196/jrc.2485.
- [14] A. S. Ismailov and Z. B. Jo’rayev, “Study of arduino microcontroller board,” *Science Educ. Sci. J.*, vol. 3, no. 3, pp. 172–179, 2022, [Online]. Available: [www.openscience.uz](http://www.openscience.uz)
- [15] S. M. Kim, Y. Choi, and J. Suh, “Applications of the open-source hardware Arduino platform in the mining industry: A review,” *Appl. Sci.*, vol. 10, no. 14, 2020, doi: 10.3390/app10145018.
- [16] S. S. Goswami and S. K. Sahoo, “Design of a Robotic Vehicle to Avoid Obstacle Using Arduino Microcontroller and Ultrasonic Sensor,” *Adv. Transdiscipl. Eng.*, vol. 42, pp. 1002–1010, 2023, doi: 10.3233/ATDE231041.
- [17] S. Gao and L. K. Bhagi, “Design and research on CADD/CAM system of plane based on NC machining technology,” *Comput. Aided. Des. Appl.*, vol. 19, no. S2, pp. 64–73, 2022, doi: 10.14733/cadaps.2022.S2.64-73.
- [18] G. Andriyanto, “Analisis Uji Statis pada Sambungan Las antara SS 201 Annealed dan AISI 4340 Steel Annealed dengan Solidworks,” pp. 1–8, 2021.
- [19] A. Sitepu and D. Briloneristen, “Penerapan Design For Manufacturing And Assembly (DFMA) Pada Jam Dinding,” *J. Energy dan Eng.*, vol. 6, no. 1, pp. 183–191, 2023, doi: 10.32734/ee.v6i1.1803.
- [20] S. Suryady and A. D. Sapto, “Pembebanan Statis terhadap Rangka Mesin Alat Pengaduk untuk Adonan Donat menggunakan Software FEA,” *J. Tek. Mesin*, vol. 13, no. 1, p. 22, 2024, doi: 10.22441/jtm.v13i1.17689.