

Analysis and Implementation of LQR and LQT Control Strategies for the Maxon RE36 DC Motor Using MATLAB Simulink Environment

Mukhammad Jamaludin¹, Anggara Trisna Nugraha², Rama Arya Sobhita³, Dimas Eka Saputra⁴

¹Bio-Industrial Mechatronics Engineering, National Chung Hsing University, Taiwan

^{2,3}Marine Electrical Engineering, Shipbuilding Institute of Polytechnic Surabaya, Indonesia

⁴Design and Manufacture Engineering, Shipbuilding Institute of Polytechnic Surabaya, Indonesia

Article Info

Article history:

Received 01

February, 2025

Revised 15 March,
2025

Accepted 10 May,
2025

Abstract

The field of automatic control plays a crucial role in advancing science and technology. Among various actuators, DC motors are widely used but are often prone to overshoot due to their high initial torque and generally unstable performance characteristics. This study aims to determine the most effective control approach for optimizing the performance of the Maxon RE36 DC motor. Two control strategies are evaluated: the Linear Quadratic Regulator (LQR) and the Linear Quadratic Tracking (LQT) method. In a first-order system analysis, the motor's output significantly deviated from the target setpoint of 1, exhibiting an overshoot of approximately 0.505%. The application of the LQR method in output response modeling effectively reached the setpoint without any occurrence of overshoot or undershoot. Conversely, the LQT method achieved the setpoint but introduced a 5.851% undershoot and a 0.7% overshoot, although it demonstrated a rapid response time, achieving steady-state within approximately ± 0.5 seconds. Experimental results on the Maxon RE36 DC motor revealed that while the LQT method offered faster settling times, the LQR method produced a cleaner response with no overshoot or ripple, making it more suitable for precision optimization of the motor's dynamic performance.

Keyword: LQR, LQT, DC Motor, Control System.

*Corresponding Author:

Name: Anggara Trisna Nugraha

Email: anggaranugraha@ppns.ac.id

1. Introduction

Automatic control systems have become a fundamental component in the evolution of science and technology. Advances in automation have enabled more efficient measurement of system performance, reduced repetitive manual labor, and enhanced productivity [1-3]. System

identification is essential for understanding the behavior of a system, and this is typically achieved by developing a mathematical model based on the system's physical components. Once the mathematical representation is derived, the corresponding transfer function can be obtained, allowing for analysis of the system's response characteristics under various inputs. This information forms the basis for designing appropriate control strategies to ensure that the system operates as desired [4].

DC motors are known for their tendency to exhibit overshoot due to their high starting torque and are often associated with unstable performance [5][6]. To analyze and understand these characteristics, it is necessary to perform system identification by modeling the motor's specifications such as those found in its datasheet into mathematical form. This process yields a transfer function, which is then used to evaluate how the system responds to a range of input signals. Although DC motors are capable of delivering rapid responses, they commonly experience steady-state error. To address such limitations, a control system must be designed. Control systems are typically implemented to handle issues such as overshoot, settling time, and overall system stability to meet specific performance requirements [7-9]. Among the various optimization control strategies available, Linear Quadratic Regulator (LQR) and Linear Quadratic Tracking (LQT) methods are widely recognized [10].

With reference to the previously discussed challenges, this paper is focused on analyzing and identifying the effectiveness of LQR and LQT as optimization control methods. Drawing from the subject of system optimization, both techniques are applied to a DC motor equipped with a detailed datasheet [11][12]. The selected motor for this study is the Maxon RE36 DC motor, which includes specifications such as moment of inertia, motor constant, damping ratio, resistance, and inductance. These parameters are implemented through MATLAB scripting and simulated in a Simulink block diagram to observe the system's step response. The study further evaluates the performance of LQR and LQT control strategies both in the presence and absence of noise, providing insights into their robustness and efficiency [13].

2. Research Method

2.1. DC Motor

Electric motors function by converting electrical energy into mechanical energy. Most electric motors operate based on the interaction between magnetic fields and current-carrying conductors, which produces rotational motion. A DC motor typically consists of key components such as a rotor and a stator. The rotor is composed of a shaft, core, armature windings, and a commutator [14]. The DC motor employed in this study is a specially designed high-speed variant. This particular type of DC motor includes a separately excited field winding, which is powered by an independent external source [15]. In such motors, both power output and rotational speed are enhanced due to the separate excitation, where the field current is supplied independently of the armature circuit, allowing for greater control and improved performance.

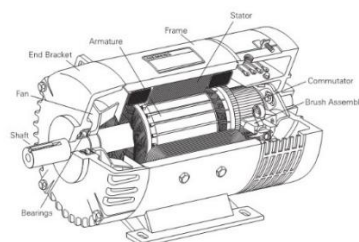

Figure 1. DC Motor

A DC motor can be represented through a combination of electrical and mechanical structural models. The electrical structure reflects the armature winding circuit, which consists of a resistance in series with the inductive impedance of the winding [16]. On the other hand, the mechanical structure includes the rotor's moment of inertia, as well as the effects of torque and friction generated by the motor's motion.

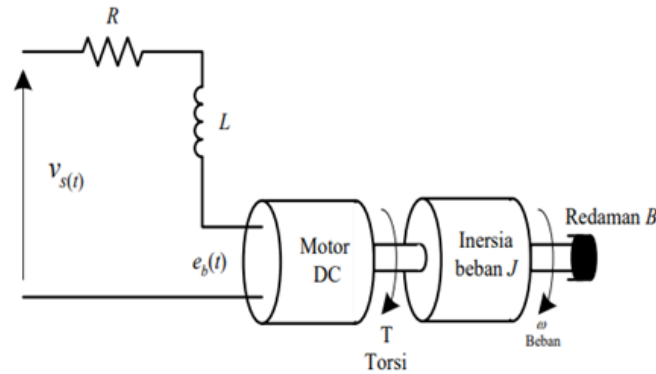

Figure 2. Model of DC Motor

The mathematical model of a first-order DC motor system is generally represented by equations (1) and (2).

$$G(s) = \frac{K}{\tau s + 1} \tag{1}$$

$$K = \frac{\tau}{i} \tag{2}$$

Desription :

- G(s) = Gen
- K = Constanta
- τ = Torque
- i = Ampere

2.2. Linear Quadratic Regulator (LQR)

The Linear Quadratic Regulator (LQR) is an optimal control strategy designed to return the system to a desired final state while minimizing a defined cost function [17]. This method focuses on determining the optimal state feedback gain (K). Consider a system, or plant, represented in state-space form as shown in Equation (3).

$$\dot{x} = Ax + Bu \tag{3}$$

Alongside its state-space representation, the system is also associated with a performance index that serves as the cost function to be minimized:

$$J = \int_0^{\infty} [x^T Qx + u^T Ru] dt \tag{4}$$

Where:

- Q = symmetric matrix, positive semi definite, real ($Q \geq 0$)
- R = symmetric matrix, positive definite, real ($R > 0$).

LQR finds the optimal control input law u^* . The constraints imposed by the Q and R matrices minimize the performance index. The closed-loop optimal control law is defined as:

$$u^* = -Kx \tag{5}$$

Here, K denotes the optimal state feedback gain matrix. This matrix functions to minimize the performance index by determining the appropriate placement of the closed-loop poles. The value of K is influenced by the system matrices A and B, as well as the weighting matrices Q and R. The optimal gain matrix K is obtained by solving the Algebraic Riccati Equation (ARE) [18]. The solution to this equation yields a symmetric and positive definite matrix P, which is defined as follows:

$$A^T P + PA - PBR^{-1}B^T P + Q = 0 \tag{6}$$

$$K = AX - BKx = (A - BK)x \tag{7}$$

Substitute equations (8) and (9) to get

$$x = AX - BKx = (A - BK)x \tag{8}$$

The block diagram showing the LQR configuration is shown in Figure 3.

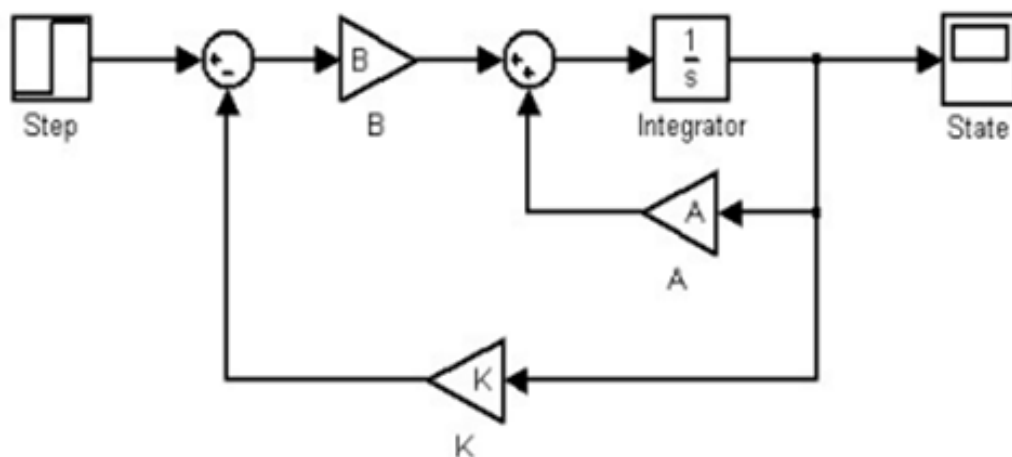

Figure 3. LQR Block Diagram

2.3. Linear Quadratic Tracking (LQT)

The Linear Quadratic Tracking (LQT) method is a linear control strategy designed to ensure that the system output accurately follows a desired reference trajectory [19]. LQT incorporates standard state feedback for linear dynamic systems, supplemented with an additional feedforward control term. This feedforward component is dependent on the reference signal vector, $r(t)$, which is expressed as follows:

$$r(t) = [V_{ref}(t) \ 0]^T \tag{9}$$

The LQT framework minimizes a quadratic performance index to determine the optimal control strategy. This objective can be formulated through the following equation:

$$e = z - y \tag{10}$$

$$J = \frac{1}{2} e'(tf)F(tf)e(tf) + \frac{1}{2} \int_0^{\infty} [x^T Qx + u^T Ru] dt \quad (11)$$

In this formulation, Q and R represent the state and control weighting matrices, respectively. These matrices are selected such that $Q = Q^T \geq 0$ and $R = R^T > 0$. Due to the quadratic nature of the cost function, the control signal is directly influenced by the squared variations in the system states. Consequently, when the deviations in state variables are large, the minimization process becomes more pronounced, leading to a faster convergence rate.

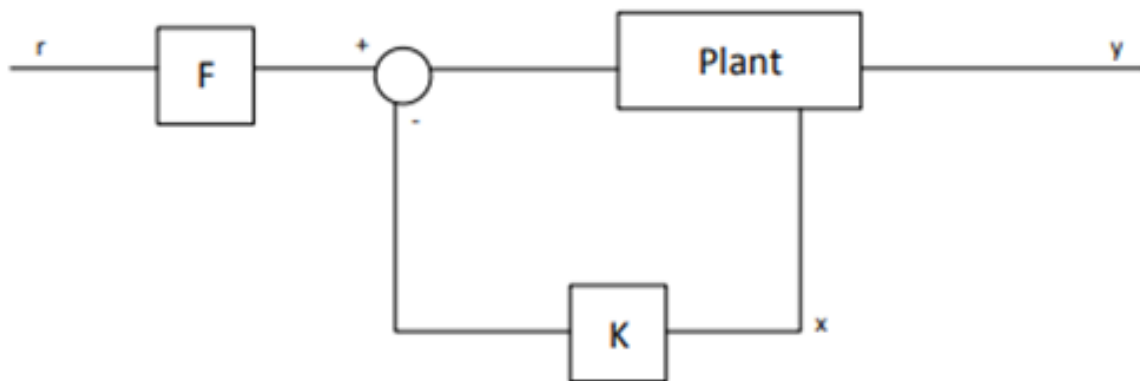

Figure 4. LQT Block Diagram

2.3. Simulation

Simulation is a learning method that utilizes real-world situations or processes to deliver instructional experiences. In this study, simulations are conducted using MATLAB software. MATLAB (short for Matrix Laboratory) is a high-level programming language and environment designed for numerical computation and analysis. Initially developed as an interface for numerical routines from the LINPACK and EISPACK projects and originally written in FORTRAN, MATLAB has since evolved into a commercial product developed by MathWorks, Inc., now written in C++ and assembler for enhanced performance [20].

To observe the dynamic response of the DC motor, the Simulink feature within MATLAB is employed. Simulink provides a graphical environment for simulating analog signals, discrete signals, and hybrid systems that involve both continuous and discrete dynamics. The simulation model also incorporates subsystem blocks to structure and manage complex components within the system.

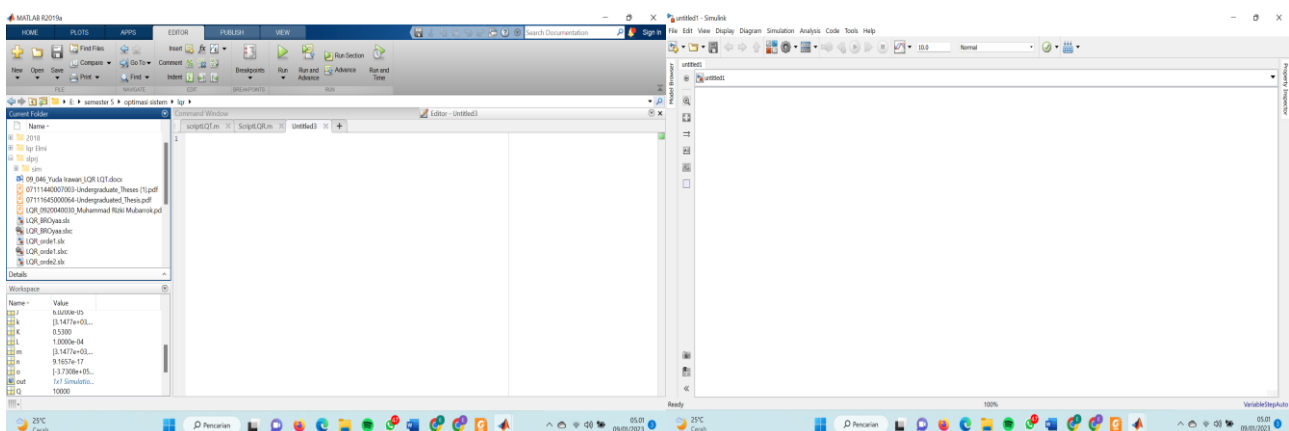

Figure 5. Interface of Matlab software and Simulink

3. Results And Discussion

3.1. DC Motor Maxon RE36 Datasheet

			118797	118798	118799	118800	118801
Motor Data							
1	Assigned power rating	W	70	70	70	70	70
2	Nominal voltage	Volt	18.0	24.0	32.0	42.0	42.0
3	No load speed	rpm	6610	6210	6790	7020	6340
4	Stall torque	mNm	730	783	832	865	786
5	Speed / torque gradient	rpm / mNm	9.23	8.05	8.27	8.19	8.14
6	No load current	mA	153	105	89	70	61
7	Starting current	A	28.6	21.5	18.7	15.3	12.6
8	Terminal resistance	Ohm	0.628	1.11	1.71	2.75	3.35
9	Max. permissible speed	rpm	8200	8200	8200	8200	8200
10	Max. continuous current	A	3.18	2.44	1.99	1.59	1.44
11	Max. continuous torque	mNm	81	88.8	88.5	89.8	90.4
12	Max. power output at nominal voltage	W	123	125	146	157	129
13	Max. efficiency	%	84	85	86	86	86
14	Torque constant	mNm / A	25.5	36.4	44.5	56.6	62.6
15	Speed constant	rpm / V	375	263	215	169	152
16	Mechanical time constant	ms	6	6	6	6	6
17	Rotor inertia	gcm ²	60.2	67.7	65.2	65.4	65.6
18	Terminal inductance	mH	0.10	0.20	0.30	0.49	0.60
19	Thermal resistance housing-ambient	K / W	6.4	6.4	6.4	6.4	6.4
20	Thermal resistance rotor-housing	K / W	3.4	3.4	3.4	3.4	3.4
21	Thermal time constant winding	s	38	43	41	41	41

Figure 6. Maxon RE 36 DC Motor Datasheet

The first-order transfer function is derived using Equation (1), resulting in the following expression:

$$K = \frac{\tau}{i} = \frac{0,081}{0,153} = 0,53$$

First order equation of DC motor:

$$G(s) = \frac{0,53}{0,081s + 1}$$

A. Design LQR Circuit on DC Motor Maxon RE 36

- Maxon RE 36 DC Motor Circuit 1st Order

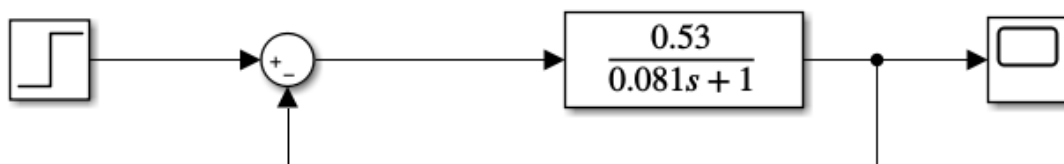

Figure 7. Maxon RE 36 DC Motor Circuit 1st Order

```

KK = [K(1) K(2)];
% Matrix LQR
Q = [1 0 0;
     0 1 0;
     0 0 1000];
R = [1];
K_lqr = lqr(AA,BB,Q,R)
KI2 = -K_lqr(3);
KK2 = [K_lqr(1) K_lqr(2)];

```

B. Design LQT Circuit on DC Motor Maxon RE 36

- LQT Circuit

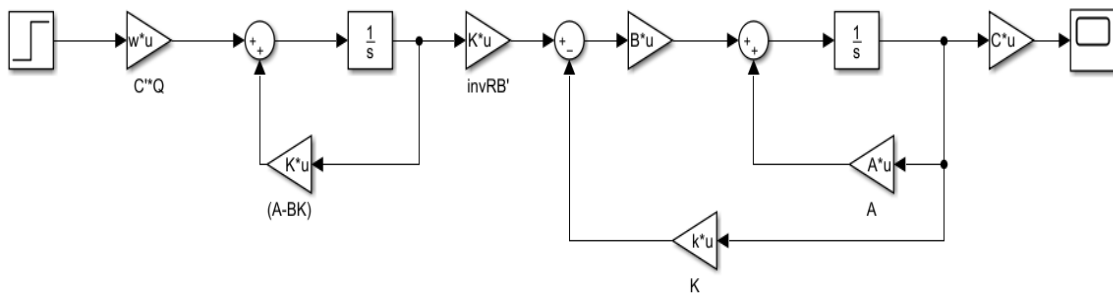

Figure 11. Maxon RE 36 DC Motor Circuit with LQT

- LQT Subsystem circuit without noise

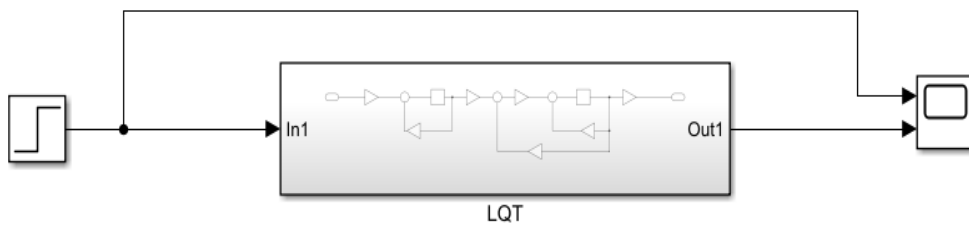

Figure 12. Subsystem LQT without noise

- LQT Subsystem circuit with noise

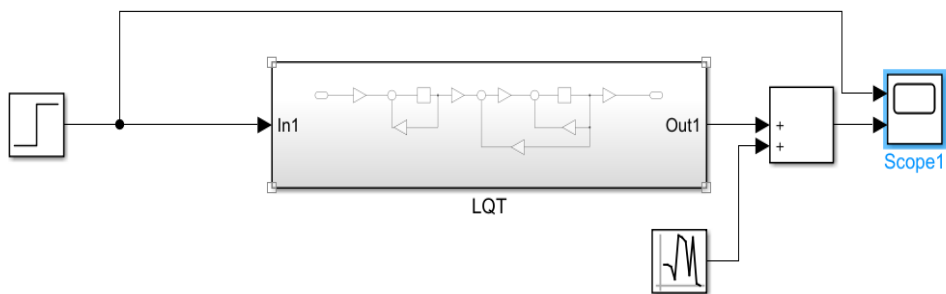

Figure 13. Subsystem LQT with noise

- Script Program LQT

```

clear; clc;
% Model Motor DC
J=0.0000602 ; b=0.1 ; K=0.53 ; R=0.628 ; L =0.0001 ;
A = [-b/J K/J; -K/L -R/L];
B = [0; 1/L];
C = [1 0];
D = 0;
Q=10000;
R=0.001;
%S=P
[S,o,m,n]=care(A,B,C'*Q*C,R);
k = inv(R)*B'*S;
w = C'*Q;
AB =(A-B*k)';
ABT = AB';
RB=inv(R)*B';

```

3.2. LQR Simulation

Table 1. Comparison result LQR Simulation

Circuit	Step Response
DC Motor Maxon RE 36 order 1	
Subsystem LQR Without noise	

Subsystem
LQR With
noise

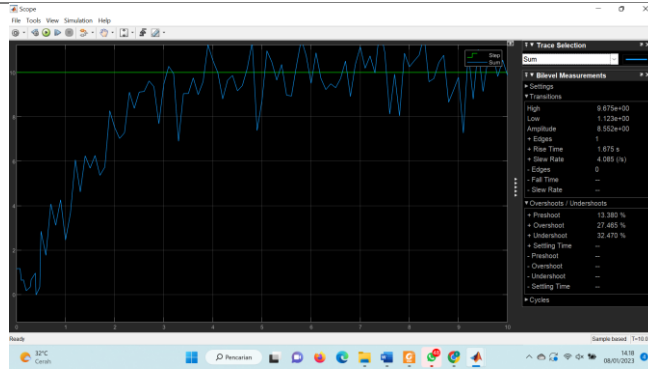

Based on the table above, the output response modeling shows that the yellow signal represents the desired setpoint, while the blue signal indicates the actual response of the Maxon RE36 DC motor. In the first-order model, the motor's output remains significantly distant from the desired setpoint value of 1. This model exhibits an overshoot of approximately 0.505%. The Maxon RE36 motor demonstrates linear characteristics, as indicated by the smooth response curve without noticeable ripple.

When using the LQR method for output response modeling, the system output aligns precisely with the target setpoint of 1. The motor's response successfully reaches the setpoint without any overshoot or undershoot. From the table, it is also evident that the yellow signal representing the LQR-based response changes in shape once noise is introduced. Although the output closely tracks the LQT-based response, it exhibits significant ripple and mimics the shape of the injected noise signal.

Table 2. Comparison result LQT Simulation

Circuit	Step Response
Motor DC Maxon RE 36 order 1	
Subsystem LQT Without noise	

Subsystem LQT With noise

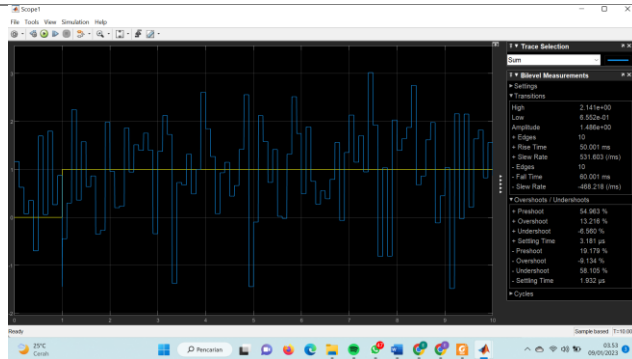

According to the table above, the yellow signal represents the desired setpoint, while the blue signal illustrates the actual output response of the Maxon RE36 DC motor. In the first-order system model, the motor's output remains notably distant from the target setpoint of 1. This first-order response exhibits an overshoot of approximately 0.505%. The observed Maxon RE36 motor shows linear behavior, as indicated by the absence of ripples in the signal waveform.

In the response modeling using the LQT method, the output successfully reaches the desired setpoint of 1. However, despite achieving the setpoint, the system experiences an undershoot of 5.851% and an overshoot of 0.7%. For a reference setpoint of 0.5, the system demonstrates a very fast rise time, reaching steady state in approximately 0.5 seconds. Nonetheless, the response initially overshoots before settling, and a small ripple becomes visible upon closer inspection of the graph. Furthermore, the table reveals that the yellow signal—representing the output response of the Maxon RE36 DC motor using the LQR method—undergoes noticeable shape changes after noise is introduced. Although the output tends to follow the trajectory produced by the LQT method, it shows more pronounced ripple and closely mirrors the characteristics of the injected noise signal.

4. Conclusion

Based on the experiments conducted on the Maxon RE36 DC motor, it can be concluded that the LQR method yields the most optimal response. This approach enables the motor to reach the desired setpoint without any overshoot or undershoot. Furthermore, the time required to reach steady state using LQR is faster compared to the system without any control method applied. However, when noise is introduced, the LQR-controlled system produces an output that mimics the injected noise, resulting in a non-linear response. Although the general trend remains similar to the noise-free case, the signal's shape reflects the characteristics of the noise. In contrast, the implementation of the LQT method results in a faster response time. Nevertheless, it is accompanied by a slight overshoot and minor ripple. When noise is introduced under LQT control, the motor response closely follows the noisy reference signal, again producing a non-linear system behavior. Overall, the LQR method is preferable for optimizing the performance of the Maxon RE36 DC motor. Despite taking slightly longer to reach steady state compared to LQT, it offers superior stability with no overshoot or ripple, making it highly suitable for precision control applications involving this type of motor.

References

- [1] Razi, M., Murgovski, N., McKelvey, T., & Wik, T. (2021). Design and comparative analyses of optimal feedback controllers for hybrid electric vehicles. *IEEE Transactions on Vehicular Technology*, 70(4), 2979-2993.

- [2] Xue, W., Fan, J., Lopez, V. G., Jiang, Y., Chai, T., & Lewis, F. L. (2020). Off-policy reinforcement learning for tracking in continuous-time systems on two time scales. *IEEE transactions on neural networks and learning systems*, 32(10), 4334-4346.
- [3] Nugraha, Anggara Trisna, et al. "PEMODELAN DAN SIMULASI OPEN LOOP SERTA CLOSE LOOP MOTOR DC TYPE 18105 ORDE 2." *Prosiding Seminar Nasional Terapan Riset Inovatif (SENTRINOV)*. Vol. 10. No. 1. 2024.
- [4] Nugraha, Anggara Trisna, and Elmi Hidayana. "Object Detection of Track Using YOLO Method in Fast Unmanned Vessel Application." *Jurnal Teknologi Maritim* 7.1 (2024): 52-62.
- [5] Yuniza, Salsabila Ika, Diego Ilham Yoga Agna, and Anggara Trisna Nugraha. "The Design of Effective Single-Phase Bridge Full Control Resistive Load Rectifying Circuit Based on MATLAB and PSIM." *International Journal of Advanced Electrical and Computer Engineering* 3.3 (2022).
- [6] Paluga, Ary Pratama, et al. "Renewable Energy System Optimization: Mppt Inverter Integration, Energy Storage Systems, And Its Impact on Sustainability and Efficiency Use Of Energy." *MEIN: Journal of Mechanical, Electrical & Industrial Technology* 1.2 (2024): 12-17.
- [7] Almunawar, Deni, et al. "Perancangan Sistem Pendukung Keputusan Mesin e-Fill Berbasis ANFIS." *COMPLETE-Journal of Computer, Electronic, and Telecommunication* 5.1 (2024).
- [8] Saputra, Fahmi Yahya, et al. "Efficiency Of Generator Set On Changes In Electrical Load On Fishery Vessels." *MEIN: Journal of Mechanical, Electrical & Industrial Technology* 1.2 (2024): 1-4.
- [9] Pangestu, Nanda Dwi, et al. "PERANCANGAN SMART PROTECTION PADA MOTOR KINCIR AERATOR TAMBAK UDANG MENGGUNAKAN LOGIKA FUZZY." *Jurnal 7 Samudra* 9.1 (2024): 1-8.
- [10] Dermawan, Deny, et al. "Pengontrol Kecepatan Respon Motor dengan Pid dan Lqr." *Seminar MASTER PPNS*. Vol. 8. No. 1. 2023.
- [11] Agna, Diego Ilham Yoga, Rama Arya Sobhita, and Anggara Trisna Nugraha. "Penyearah Gelombang Penuh 3 Fasa Tak Terkendali dari Generator Kapal AC 3 Fasa." *Seminar MASTER PPNS*. Vol. 8. No. 1. 2023.
- [12] Apriani, Mirna, et al. "Coastal Community Empowerment Recovery of cockle shell waste into eco-friendly artificial reefs in Mutiara Beach Trenggalek Indonesia." *Frontiers in Community Service and Empowerment* 1.4 (2022).
- [13] Nugraha, Anggara Trisna, and Rachma Prilian Eviningsih. *Penerapan Sistem Elektronika Daya: AC Regulator, DC Chopper, dan Inverter*. Deepublish, 2022.
- [14] Sheila, Sindy Yurisma, et al. "Coffee Drying Tool with LQR-PID Control." *MEIN: Journal of Mechanical, Electrical & Industrial Technology* 1.2 (2024): 18-23.
- [15] Prastyawan, Rikat Eka, and Anggara Trisna Nugraha. "PENERAPAN TEKNOLOGI INFORMASI UNTUK PEMBELAJARAN TEST OF ENGLISH FOR INTERNATIONAL COMMUNICATION PREPARATION." *Jurnal Cakrawala Maritim* 5.1 (2022): 4-8.
- [16] Ainudin, Fortunaviaza Habib, Muhammad Bilhaq Ashlah, and Anggara Trisna Nugraha. "Pengontrol Kecepatan Respon Motor dengan Pid dan Lqr." *Seminar MASTER PPNS*. Vol. 7. No. 1. 2022.
- [17] Sasongko, Adhy, et al. "Estimation of the thrust coefficient of a Quadcopter Propeller using Computational Fluid Dynamics."
- [18] Putra, Z. M. A., Nugraha, A. T., Widiarti, Y., Safaroz, W., & Sobhita, R. A. (2024). Design of Unipolar Pure Sine Wave Inverter with Spwm Method Based On Esp32 Microcontroller As a Support of The Ebt System On Ship. In *E3S web of conferences* (Vol. 473, p. 01008). EDP Sciences.

- [19] Magriza, Rania Yasmin, et al. "Design and Implementation of Water Quality Control in Catfish Farming Using Fuzzy Logic Method with IoT-Based Monitoring System." *Jurnal Teknologi Maritim* 4.1 (2021): 13-18.
- [20] Dermawan, Deny, et al. "Kendali Kecepatan Motor Dengan Kontrol Pid Menggunakan Metode Metaheuristik." *Seminar MASTER PPNS*. Vol. 8. No. 1. 2023.